

PRODUCT DATA SHEET

Part #: PD13WRNZAB1014-T • NSN: 5410-01-626-8712

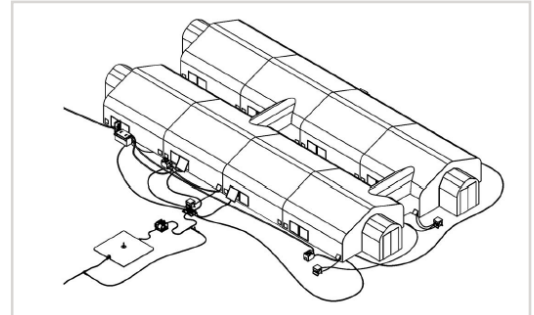

MULTI-PURPOSE AREA SHELTER SYSTEM (TYPE I)-40'x80'-TAN

CONTRACTOR NAME: CELINA Tent, Inc.			
1. PART NUMBER: PD13WRNZAB1014-T		2. NSN: 5410-01-626-8712	
3. NAME: Multi-purpose Area Shelter System, Type-I	4. TYPE: Frame Structure, Expandable, Air-Transportable	5. CLASS: 03294	
6. COLOR: Tan	7. SUPPORT SYSTEM: Frame	8. SERIES: C27	
9. INTENDED USE: Multi-purpose Utility Shelter, Kitchen, Billeting, General Purpose, Command Post			
10. DIMENSIONS (IN FEET AND INCHES):	LENGTH: 94'6"	WIDTH: 48'2"	HEIGHT: RIDGE: 12'11" EAVE: 7'1"
11. DIMENSIONS (EXTERNAL GUYED):	LENGTH: N/A	WIDTH: N/A	
12. SQUARE FEET INTERIOR: 3,200 sq. ft.			
13. WEIGHT (POUNDS, UNPACKAGED): 24,000 lbs	14. WEIGHT (PACKAGED): 28,650 lbs	15. SHIPPING CUBE (PACKAGED): 1,360 Cubic Feet	
16. SHIPPING CONTAINER: 20' ISO Shipping Container	LENGTH: 20'0"	WIDTH: 8'0"	HEIGHT: 8'6"
17. SET-UP TIME/NUMBER OF PERSONS: 6 People/12 Hours		18. STRIKE TIME/NUMBER OF PERSONS: 6 People/6 Hours	
19. PARTS INCLUDED (Include Quantity): (1) Aluminum Frame, (1) Fabric Cover, (1) Insulated Liner (1) Vinyl Non-Slip Floor, (4) 60" x 82" Latching Hard Double Doors (1 Per End Wall), (4) 6.5'W X 6'L X 7'H Vestibules with a Soft Zipper Door to Interface with End Wall Hard Doors, (4) 50" x 81" Sidewall Soft Doors, (2) 6.5'W X 6'L X 7'H Corridors to Interface with Soft Side Wall Doors, (16) 18" Dia. HVAC Ports, (16) 14" Dia. Utility Ports, (32) 8" Dia. Electrical Ports, (4) Internal Plenums, (4) Exhaust Ports, (1) Spare/Repair Kit, (1) Anchoring System, (1) 20' ISO Shipping Container			
20. DESCRIPTION: CELINA's Multi-purpose Area Shelter System (Type I) is designed to provide increased environmental protection and energy efficiency to the warfighter. The shelter is a field-proven subsystem within the U.S. Air Force's BEAR Kitchen System, and has been deployed to numerous locations worldwide. The system is supported by a lightweight, rigid framework and designed to be deployed within a moment's notice. It is transported in all shipping configurations (land, air and sea), and easily erected. CELINA's Multi-purpose Area Shelter System is Berry Compliant and capable of being extended or complexed.			

PRODUCT DATA SHEET

Part #: PD13WRNZAB1014-T • NSN: 5410-01-626-8712



21. ACCESSORY AND SUPPORT EQUIPMENT:

OPTIONAL ACCESSORIES: Call for optional accessories; light sets, electrical outlet sets, flooring, heaters, air conditioners, generators, power distribution, insulated liners, and insulated flooring.

22. SNOW LOAD:
10 PSF

23. WIND LOAD:
90 MPH

24. RAIN LOAD:
4" per hour with 40 mph winds

